

May 2004

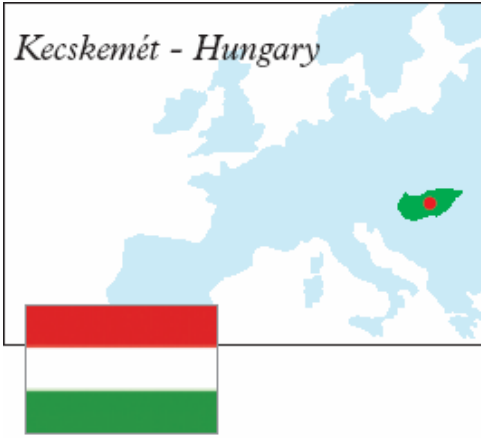

Customer presentation

Bacsviz pumping station Kecskemét Hungary

The "N°.2. Vizműtelep" pumping station is operated by the company. It supplies (with the pumping station "N°.1") the town and region of Kecskemét, i.e. 120.000 inhabitants. Natural drinking water is extracted from a depth of more than 300 metres and the site has a pumping capacity of 30.000 m3 per day.

Bacsviz employs 600 people, manages the drinking water supply and its re-treatment for the region of Bacs-Kiskun with a capacity of 101.400 m3 per day.

The "N°.2. Vizműtelep" pumping station has an average electrical consumption of 500kWh in the winter and 700kWh in the summer, i.e. an average consumption per m3 of 0.7kWh

For more informations contact:



Market data

•Infrastructure

↳others :

Pumping station

Customer need

Monitor the site's electrical consumption profile to allow the customer to optimise his electricity supply contract and to make energy and cost savings.

Key words

- Country
- Products
- Needs
- Segments

Benefits

"The first two consumption monitoring reports, i.e. after six months' operation, have provided us with new information on the pumping station operation and can help us to optimize the energy consumption cost. We wish to extend the e-analysis to the N°.1 pumping station to ensure the complete supervision of our electrical equipment on 2 pumping stations at Kecskemét." **(The opinion of Bacsviz's technical director)**

Schneider solution

Continuously analyse, via the Internet, all the parameters (energy, power, current, voltage, etc.) of the pumping stations electrical distribution network applications and supply an indicator chart, continuously updated, and designed to:

- Manage the electricity supply contract with respect to electrical installation operating conditions
- Propose solutions recommending potential energy and cost savings.

Step of project

Schneider Electric Services Hungary offered Bacsviz an e-analysis service with remote monitoring of their electrical installation.

This installation includes two distribution switchboards located in two buildings 300 m apart. The first switchboard is dedicated to subsurface and pressure pumps for the distribution network, while the second switchboard is dedicated to compressed air producing and airblowing for filter cleaning.

This global service is offered via the Internet and includes:

- monitoring of the electrical installation with 8 Power Meters, 1 EGX and 1 eSBox by Merlin Gerin,
- configuration of devices according to the electrical consumption analysis and aims,
- interpretation of the information by Schneider Electric Services experts by means of expert software,
- recommendations thanks to quarterly reports,
- creation of a confidential database on the Internet accessible by Bacsviz engineers via an authentication process.

Architecture

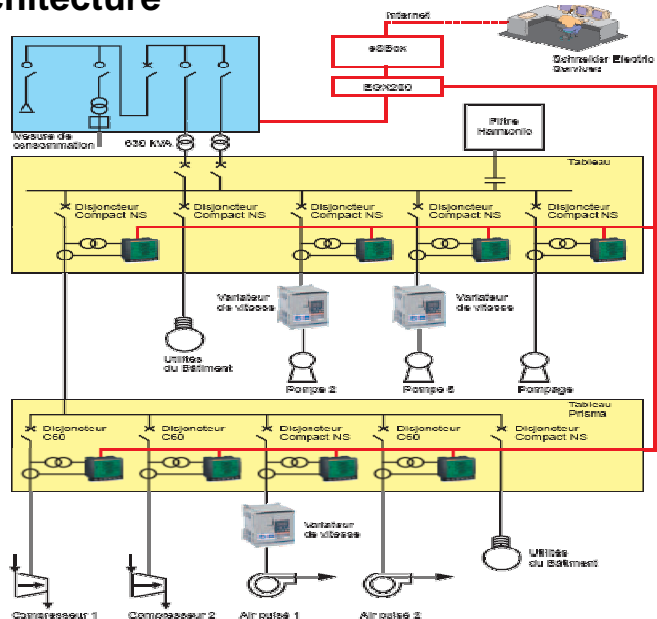

Products

- Power Meter
- EGX
- eSBox

Schneider Electric industries SAS

As standards, specifications and designs change from time to time, please ask for confirmation of the information given in this publication.

Design: Schneider Electric
Publication: Schneider Electric